

## AIRIUS STVS1 SMART SPEED CONTROLLER 5 AMP



**Ideal for BMS  
& Fire System  
Integration**

Airius Model	10/S3	15/S2	25/S1	45/PS-4	Onyx PS-4	50/PS-4	60/PS-4	G400/PS-4
No. of Units	74	57	35	21	14	14	7	5

### MOUNTING

The controllers are to be mounted on a smooth surface. Connect voltage supply, motor(s) and earth as shown in the scheme with cables of the proper diameter. On the mains side, a safety switch with recommend pre-fuses has to be installed.

### TRANSPORT AND STOCK KEEPING

Avoid shocks and extreme conditions, stock in original packaging.

### WARRANTY

Two years from delivery date against defects in manufacturing. Any modifications or alterations to the product relieve the manufacturer of all responsibility. The manufacturer bears no responsibility for any misprints or mistakes in this data, and modifications or improvements to the product can be made at any time after date of publication.

### KEY FEATURES

- Analogue input signal (0–10 VDC) galvanically isolated
- TK monitoring for thermal motor protection
- 5 switching levels according to the input signal
- LED status indication
- +12 VDC output (e.g. as supply for MTP-X10K potentiometer from Sentera)

### TECHNICAL DATA

**Voltage:** 230Vac – 50/60Hz  
**Weight:** 5.5 kg  
**IP Rating:** IP54

	<b>MAX AMPS</b>	<b>FUSE</b>
<b>STR-1-50L22</b>	5.0	(5* 20 mm) T-8,0 A-H

**Enclosure:** Plastic R-ABS, UL94-V0, grey RAL 7035 or sheet steel (RAL 7032, polyester powder coating).

**Recommended prim. Fuse:** ca 1,5 x trafo.  
**Max ambient temperature:** 35°C

The STVS1 series of transformer fan speed controllers regulate the rotational speed of single-phase voltage controllable motors in five steps by varying the output voltage according to an 0–10 VDC analogue input signal. They are equipped with autotransformer(s) and feature TK monitoring for thermal motor protection.

### MAINTENANCE

In normal conditions the controllers are maintenance-free. If soiled clean with dry or dampish cloth. In case of heavy pollution clean with a non-aggressive product. In these circumstances the controller should be disconnected from the mains. Pay attention that no fluids enter the controller. Only reconnect the controller to the mains when it is completely dry.

### MOTOR PROTECTION

It is always recommended to install a proper motor protection device.

All works may only be carried out by skilled personnel following the local regulations and AFTER the controller is completely separated from the mains. Replace fuse only with same type and rating.

According to the low voltage directive: 2006/95/EC/  
The EMC directive: 2004/108/EC



### MOTOR DATA





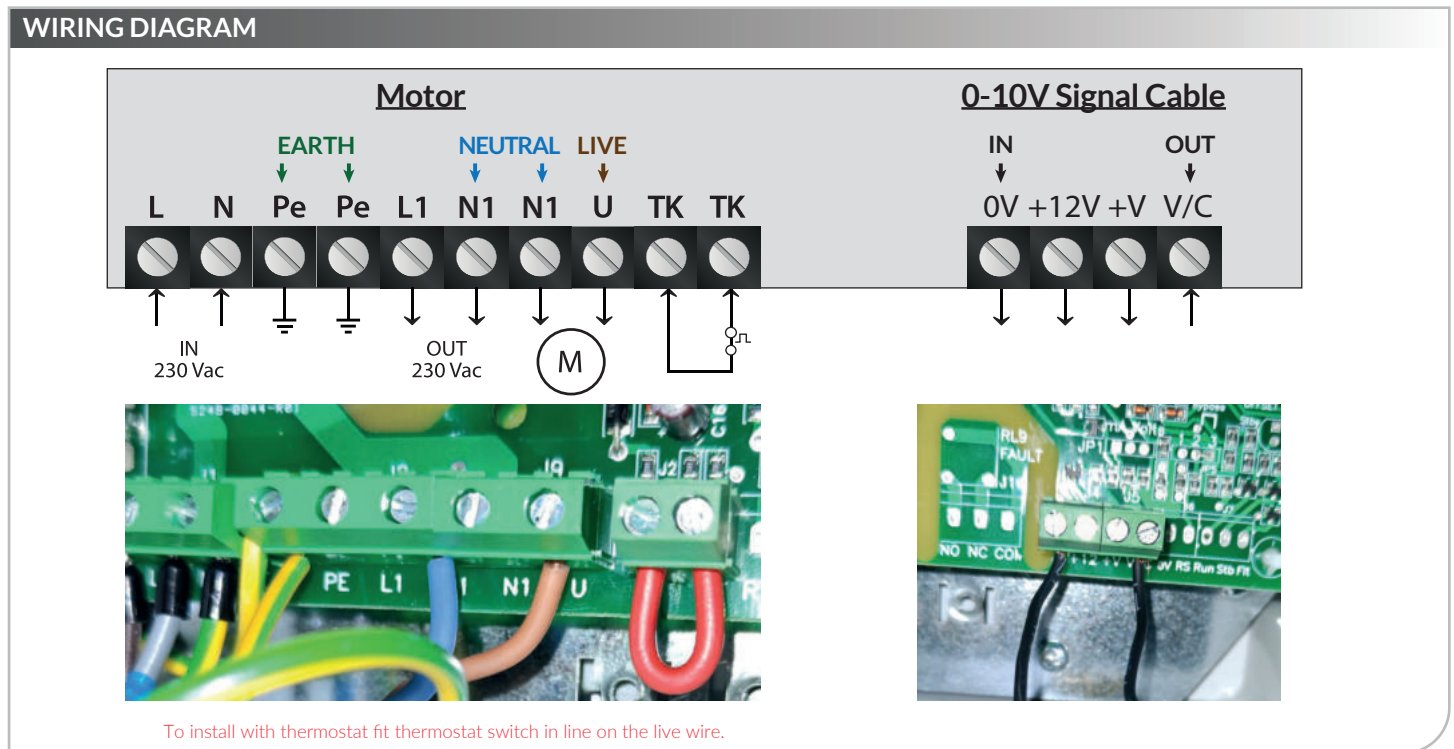
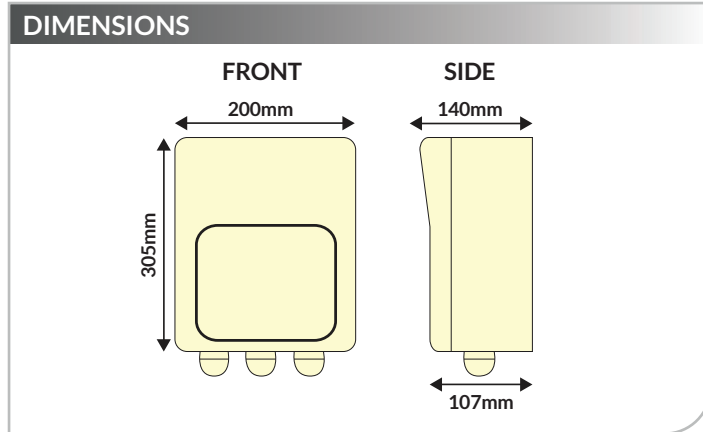

Control signal input:	0–10 VDC
Output:	12 VDC / I <sub>max</sub> 50 mA
Unregulated output:	230 VAC (max. 2 A)
Switching levels	Switching levels
Up:	2; 4; 6; 8; 9,5 VDC
Down:	Up level – 0,2 VDC
Max. Rel. humidity:	5–95 % rH (non-condensing)

## AIRIUS STVS1 SMART SPEED CONTROLLER 5 AMP



**PLEASE NOTE: THIS CONTROLLER MUST BE EARTHED**

**VOLTAGE**

0–10 VDC or external potentiometer positions (MTVor MTP)*	0	-	1	2	3	4	5
Wires		-					
			<b>Regulated Output (VAC)</b>				
Voltages**	0	80***	110	140	170	190	230
			<b>Unregulated Output (VAC)</b>				
L1	0	230	230	230	230	230	230

\* See the operational diagram on the next page for the corresponding voltages.  
\*\* If more than 5 output voltages are available, adjust the 5 steps by changing the internal wiring.  
\*\*\* Available but not connected.

**WIRING & CONNECTIONS**

L	Power supply, phase (230 VAC / 50–60 Hz)
N	Power supply, neutral
Pe	Earth terminal
L1	Unregulated output, line
N1	Unregulated output, neutral
U	Regulated output to motor, line
TK	Input - TK monitoring for thermal motor protection
0V	Ground
+12V	Output 12 VDC / I <sub>max</sub> 50 mA
+V*	Digital output 12 VDC / I <sub>max</sub> 50 mA (0 VDC = TK fault; 12 VDC = normal operation)
V/C	Input U: 0–10 VDC